

LIQUID SOAP DISPENSER WP173-1 FOR MOUNTING IN CABINET



67 x 150 x 88 mm

200 ml soap tank

- Liquid soap dispenser in robust, germ-reducing and easy-care stainless steel (AISI 316L).
- For mounting in cabinet on site.
- One-hand operated and non-drip soap pump with 200 ml tank.
- Tank with large, lockable refill opening.
- Designed for standard liquid soaps or hand lotions. Refillable from the top.
- Wear parts can be replaced as modules.
- Mounting: With two screws through key holes and one optional anti-theft hole in the back wall.
- Delivery includes fixing material and self-adhesive information label „Soap“.
- Weight, including single package: 0.7 kg



Suggested text for specifications:

Liquid soap dispenser in stainless steel (AISI 316L) for mounting in cabinet. One-hand operated and non-drip soap pump with 200 ml tank. Designed for standard liquid soaps or hand lotions. Refillable from the top. Delivery includes fixing material and self-adhesive information label „Soap“.

Dimensions: 67 x 150 x 88 mm

Article No. WP173-1

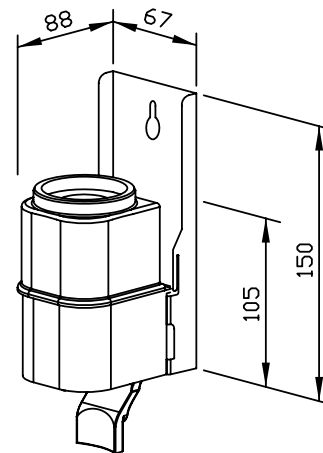

Available surface	ID No.
satin finished	727 174

Ernst Wagner GmbH & Co. KG

Ernst-Abbe-Straße 21 · D-72770 Reutlingen · Tel.: +49712151539-0 · Fax: -20
info@wagner-ewar.de · www.wagner-ewar.de

WAGNER
EWAR